

Proper Brake Adjustment

Improper brake adjustment can lead to brake pads overheating due to not being fully disengaged during operation, or brakes that do not hold completely when handle is completely pulled.

Brake

1. Crank arms to be in down position and stabilized with gearbox sheave chained off
2. Insure brake mounting bolt (1) to gearbox is tight , then tighten nut (18)
3. Place brake handle (32) in the most forward position (fully disengaged), to release the brake handle completely freely
4. Completely disengage off the SECURITY BRAKE bolt (11) by loosening the two nuts (one full and other half nut), backing off to the end of the bolt. Tighten one nut against the other to stabilize. See *
5. Back off spring adjustor nut (7) until a minimum clearance of 1mm (about the thickness of a credit card) is achieved between brake pads (5) and brake hub (17). Tighten half nut (8) against the full nut (7).
6. Insure horizontal brake pull arm (16) is in the horizontal position. (*Note: do not adjust security brake bolt 11*). This is the “fully disengaged” position for the brake assembly.

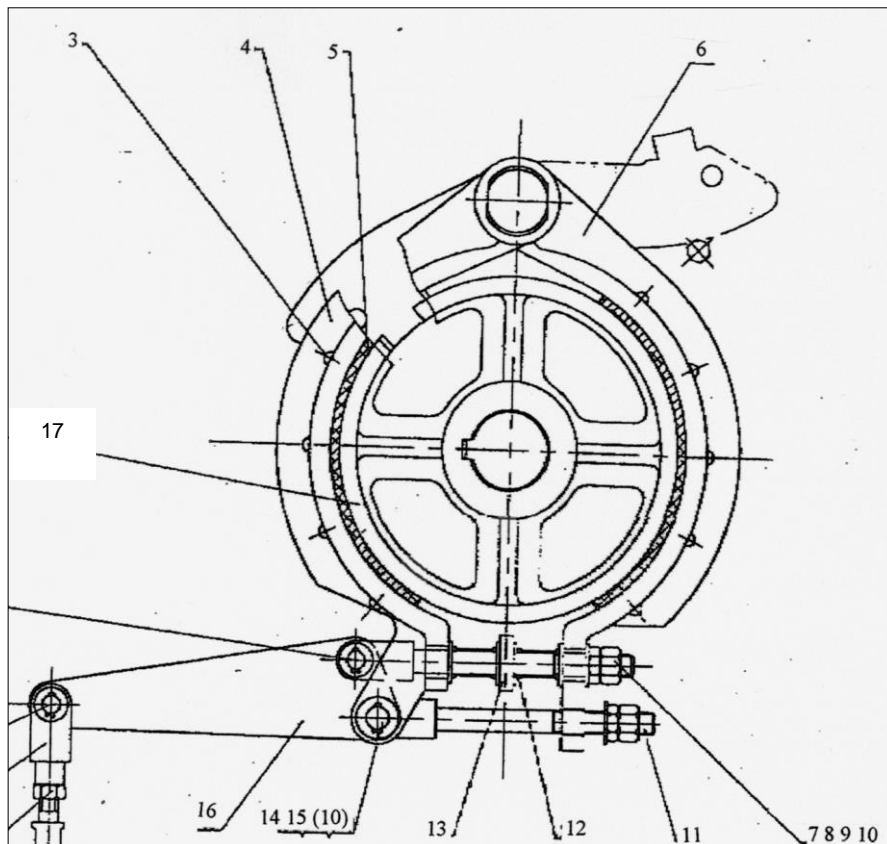

Brake Handle and Linkage

7. Install upper end of vertical brake rod (25) to horizontal pull arm (16)
8. Install lower end of vertical brake rod (25) to long arm of brake cam assembly (28) positioned such that the vertical pull rod hangs vertically. *Note: yoke end fittings on both ends of brake rods are left and right threaded allowing for expansion or contraction of pull rod length by torquing brake rod.*
9. With brake handle (32) in most forward position (fully disengaged), install horizontal brake rod (29) to brake handle and to shorter arm of brake cam assembly (see sketch below). Adjust length of horizontal rod by applying left or right torque.

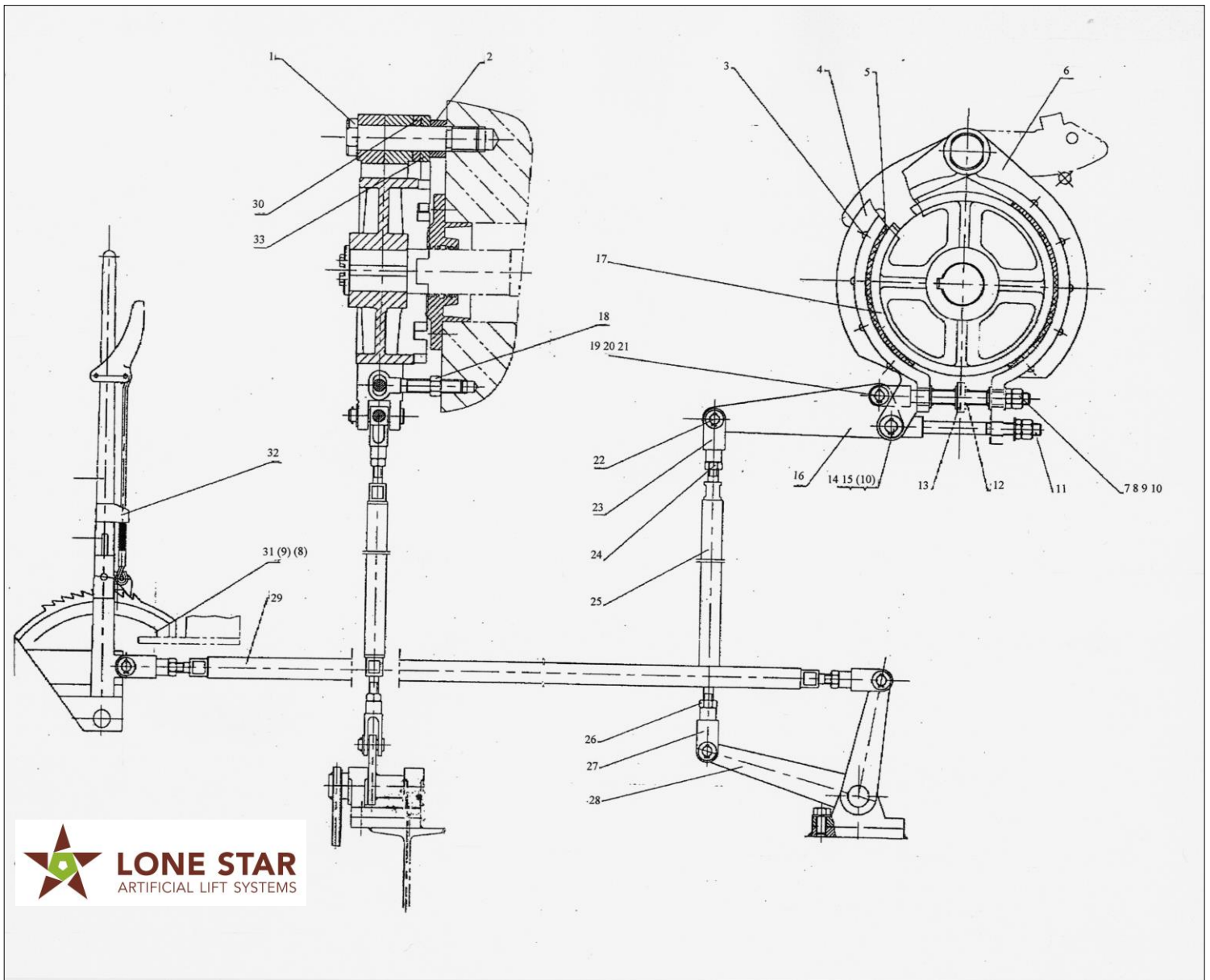

10. Adjust lengths of both vertical rod (25) and horizontal rod (29) to make the length ends of the vertical rod and the horizontal rod thread into the connectors is equal approx.
11. Test play by pulling handle back. Brake shoes should be fully engaged with brake handle in middle position. Over time as pads wear brake handle will need to be pulled farther back to engage brake.
12. Push brake handle fully forward and inspect brake to insure 1mm clearance between pads and hub. Make minor adjustments by torquing horizontal and vertical brake rods.
13. Tighten self-lock nuts at ends of both horizontal rod (29) and vertical rod (25)

** The nuts on SECURITY BRAKE BOLT (11) are always to be positioned at the end of the bolt during operation of the pumping unit. These nuts are for security only and are to be tightened only when the unit is stopped or during transportation. When the nuts are tightened, the brake pawl shall be engaged into the groove on the brake hub. The function of the SECURITY BRAKE BOLT (11) is only for added security at these times.*